

Extension 2 2009 Solution

Q1

(a)  $\int \frac{\ln x}{x} dx = \frac{1}{2}(\ln x)^2 + C.$

(b)  $\int xe^{2x} dx.$

Let  $u = x, du = dx$ ; let  $dv = e^{2x} dx, v = \frac{1}{2}e^{2x}.$

$\int xe^{2x} dx = \frac{1}{2}xe^{2x} - \frac{1}{2}\int e^{2x} dx = \frac{1}{2}xe^{2x} - \frac{1}{4}e^{2x} + C.$

(c)  $\int \frac{x^2}{1+4x^2} dx = \frac{1}{4}\int \frac{4x^2+1-1}{1+4x^2} dx$   
 $= \frac{1}{4}\left(x - \frac{1}{2}\tan^{-1}(2x)\right) + C.$

(d)  $\int_2^5 \frac{x-6}{x^2+3x-4} dx = \int_2^5 \frac{x-6}{(x+4)(x-1)} dx$   
 $= \int_2^5 \left(\frac{2}{x+4} + \frac{-1}{x-1}\right) dx = \left[2\ln(x+4) - \ln(x-1)\right]_2^5$   
 $= 2\ln\frac{9}{6} - \ln\frac{4}{1} = \ln\frac{9}{4} - \ln 4 = \ln\frac{9}{16}.$

(e)  $\int_1^{\sqrt{3}} \frac{1}{x^2\sqrt{1+x^2}} dx = \int_1^{\sqrt{3}} \frac{1}{x^3\sqrt{\frac{1+x^2}{x^2}}} dx$   
 $= \int_1^{\sqrt{3}} \frac{1}{x^3\sqrt{1+x^2}} dx = \int_1^{\sqrt{3}} \frac{1}{x^3\sqrt{\frac{1}{x^2}+1}} dx.$

Let  $u = \frac{1}{x^2}, du = -\frac{2}{x^3} dx.$

When  $x = 1, u = 1$ ; when  $x = \sqrt{3}, u = \frac{1}{3}.$

$I = -\frac{1}{2}\int_1^{\frac{1}{3}} \frac{du}{\sqrt{u+1}} = \left[\sqrt{u+1}\right]_{\frac{1}{3}}^1$   
 $= \sqrt{2} - \sqrt{\frac{4}{3}} = \sqrt{2} - \frac{2}{\sqrt{3}} = \frac{\sqrt{6}-2}{\sqrt{3}}.$

Alternatively,

Let  $x = \tan \theta, dx = \sec^2 \theta d\theta.$

When  $x = 1, \theta = \frac{\pi}{4}$ ; when  $x = \sqrt{3}, \theta = \frac{\pi}{3}.$

$I = \int_{\frac{\pi}{4}}^{\frac{\pi}{3}} \frac{\sec^2 \theta}{\tan^2 \theta \sec \theta} d\theta = \int_{\frac{\pi}{4}}^{\frac{\pi}{3}} \frac{\sec \theta}{\tan^2 \theta} d\theta =$   
 $= \int_{\frac{\pi}{4}}^{\frac{\pi}{3}} \frac{\cos \theta}{\sin^2 \theta} d\theta = \left[-\frac{1}{\sin \theta}\right]_{\frac{\pi}{4}}^{\frac{\pi}{3}} = \sqrt{2} - \frac{2}{\sqrt{3}}.$

Q2

(a)  $i^9 = i^8 \cdot i = i, \text{ since } i^4 = 1.$

(b)  $\frac{-2+3i}{2+i} = \frac{-2+3i}{2+i} \times \frac{2-i}{2-i} = \frac{-4+3+6i+2i}{5}$   
 $= \frac{-1+8i}{5}$

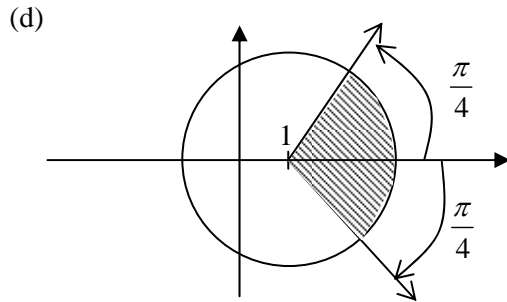
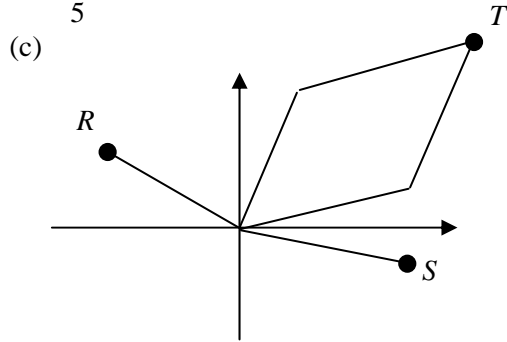

(e) (i)  $\sqrt[5]{-1} = \sqrt[5]{\text{cis}(\pi + 2k\pi)} = \text{cis} \frac{\pi + 2k\pi}{5}, k = 0, \pm 1, \pm 2.$

$\therefore \sqrt[5]{-1} = \text{cis} \frac{\pm\pi}{5}, \text{cis} \frac{\pm 3\pi}{5}, \text{cis} \pi (= -1).$

(ii)

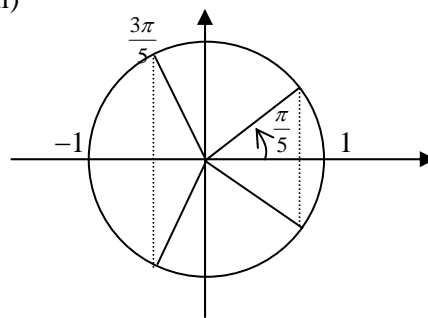

(f) (i)  $\sqrt{3+4i} = \sqrt{2^2 - 1^2 + 2 \times 2 \times 1 \times i} = \pm(2+i)$

(ii)  $z = \frac{-i \pm \sqrt{i^2 + 4(1+i)}}{2} = \frac{-i \pm \sqrt{3+4i}}{2}$   
 $= \frac{-i \pm (2+i)}{2} = \frac{2}{2} = 1 \text{ or } \frac{-2-2i}{2} = -1-i.$

**Q3**

(a)

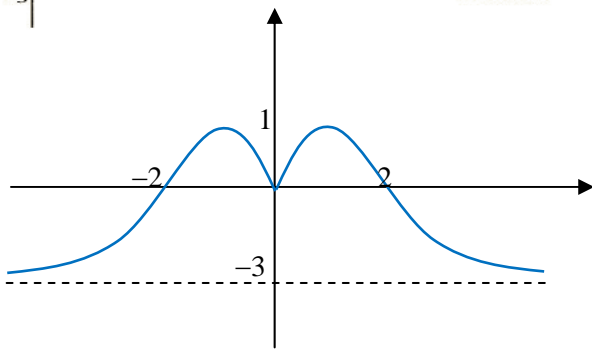
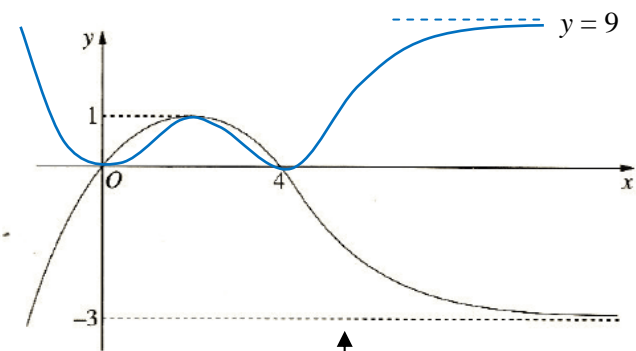
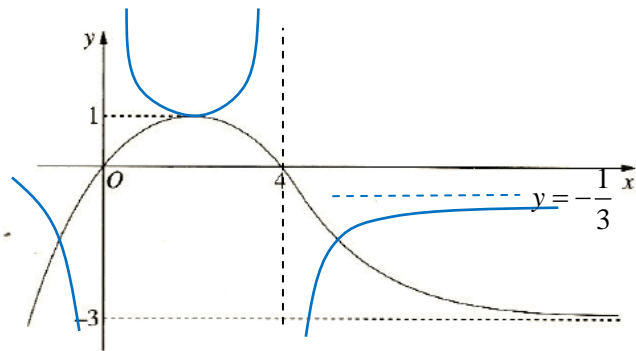

(b)  $2x + 2(y + xy') + 6yy' = 0.$

$x + y + y'(x + 3y) = 0.$

$y' = -\frac{x + y}{x + 3y}.$

Horizontal tangent,  $\therefore y' = 0, \therefore y = -x.$

Sub. to the original equation,

$x^2 - 2x^2 + 3x^2 = 18.$

$2x^2 = 18.$

$x^2 = 9.$

$x = \pm 3.$

$\therefore$  The points are  $(3, -3), (-3, 3).$

(c)  $P'(x) = 3x^2 + 2ax + b.$

$P(1) = 0, \therefore 1 + a + b + 5 = 0, \therefore a + b + 6 = 0.$

$P'(1) = 0, \therefore 3 + 2a + b = 0.$

Solving simultaneous equations gives  $a = 3, b = -9.$

(d)  $x + 1 = (x - 1)^2.$

$x + 1 = x^2 - 2x + 1.$

$-x^2 + 3x = 0.$

$\therefore x = 0, 3.$

$V = 2\pi \int_0^3 x(y_2 - y_1) dx = 2\pi \int_0^3 x(x + 1 - (x - 1)^2) dx$

$= 2\pi \int_0^3 x(-x^2 + 3x) dx = 2\pi \int_0^3 (-x^3 + 3x^2) dx$

$= 2\pi \left[ -\frac{x^4}{4} + x^3 \right]_0^3 = \frac{27\pi}{2} \text{ units}^3.$

**Q4**

(a)

(i)  $\frac{2x}{a^2} + \frac{2yy'}{b^2} = 0.$

$y' = -\frac{b^2x}{a^2y}.$

$m_1 = -\frac{b^2x_0}{a^2y_0}, \therefore m_2 = \frac{a^2y_0}{b^2x_0}.$

The equation of the normal is

$y - y_0 = \frac{a^2y_0}{b^2x_0}(x - x_0).$

(ii) Let  $y = 0,$

$-y_0 = \frac{a^2y_0}{b^2x_0}(x - x_0).$

$x - x_0 = -\frac{b^2x_0}{a^2}.$

$x = x_0 - \frac{b^2x_0}{a^2} = x_0 \left( 1 - \frac{b^2}{a^2} \right) = x_0 \left( 1 - \frac{a^2(1 - e^2)}{a^2} \right)$

$= e^2x_0.$

$\therefore N(e^2x_0, 0).$

(iii)  $\frac{PS}{PS'} = \frac{ePM}{ePM'} = \frac{\frac{a}{e} - x_0}{x_0 + \frac{a}{e}} = \frac{a - ex_0}{a + ex_0}.$

$\frac{NS}{NS'} = \frac{ae - e^2x_0}{e^2x_0 + ae} = \frac{a - ex_0}{ex_0 + a}.$

$\therefore \frac{PS}{PS'} = \frac{NS}{NS'}.$

(iv) In  $\triangle PNS', \frac{\sin \alpha}{\sin \angle PNS'} = \frac{NS'}{PS'}.$

In  $\triangle PNS, \frac{\sin \beta}{\sin \angle PNS} = \frac{NS}{PS}.$

But  $\angle PNS = \pi - \angle PNS', \therefore \sin \angle PNS = \sin \angle PNS',$

and since  $\frac{PS}{PS'} = \frac{NS}{NS'}, \therefore \frac{NS}{PS} = \frac{NS'}{PS'}.$

$\therefore \sin \alpha = \sin \beta.$

$\therefore \alpha = \beta, \text{ since } \alpha + \beta < \pi.$

(b)

(i) Resolving the forces on  $P$ ,  
vertically,  $T \cos \alpha + N \sin \alpha = mg$ , (1)

horizontally,  $T \sin \alpha - N \cos \alpha = mr\omega^2$ . (2)

(ii) (1)  $\times \cos \alpha +$  (2)  $\times \sin \alpha$  gives

$$T(\cos^2 \alpha + \sin^2 \alpha) = m(g \cos \alpha + r\omega^2 \sin \alpha).$$

$$\therefore T = m(g \cos \alpha + r\omega^2 \sin \alpha).$$

(1)  $\times \sin \alpha -$  (2)  $\times \cos \alpha$  gives

$$N(\sin^2 \alpha + \cos^2 \alpha) = m(g \sin \alpha - r\omega^2 \cos \alpha).$$

$$\therefore N = m(g \sin \alpha - r\omega^2 \cos \alpha).$$

(iii) When  $T = N$ ,

$$g \cos \alpha + r\omega^2 \sin \alpha = g \sin \alpha - r\omega^2 \cos \alpha$$

$$r\omega^2(\sin \alpha + \cos \alpha) = g(\sin \alpha - \cos \alpha).$$

$$\omega^2 = \frac{g(\sin \alpha - \cos \alpha)}{r(\sin \alpha + \cos \alpha)}$$

$$= \frac{g}{r} \left( \frac{\tan \alpha - 1}{\tan \alpha + 1} \right), \text{ by dividing both top and bottom}$$

by  $\cos \alpha$ .

(iv)  $\omega^2 > 0, \therefore \tan \alpha - 1 > 0, \therefore \tan \alpha > 1, \therefore \frac{\pi}{4} < \alpha < \frac{\pi}{2}$ .

### Q5

(a)

(i)  $\angle ADB = 90^\circ$  (semi-circle angle)

$\angle ABD = 90^\circ - \angle BAD$  (angle sum in  $\triangle ADB$ )

$\angle AKY = 90^\circ - \angle BAD$  (angle sum in  $\triangle AKY$ ).

$$\therefore \angle AKY = \angle ABD.$$

Alternatively, prove  $\triangle DXK \parallel \triangle XYB$ .

(ii)  $\angle AKX = \angle ABD$  (from above).

$\angle ABD = \angle ACD$  (angles subtending the same arc are equal).

$$\therefore \angle AKX = \angle ACD.$$

$\therefore CKDX$  is cyclic (angles subtending the same chord are equal).

(iii)  $\angle ACK = 180^\circ - \angle XDK$  (opposite angles in a cyclic quad are supplementary).

But  $\angle XDK = 90^\circ, \therefore \angle ACK = 90^\circ$ .

And  $\angle ACB = 90^\circ$  (semi-circle angle).

$\therefore B, C$  and  $K$  are collinear.

Alternatively, since  $\angle D = 90^\circ, KX$  is the diameter,

$$\therefore \angle KCX = 90^\circ.$$

(b)

(i) Let  $u = x^{2n}, du = 2nx^{2n-1}$ , and  $dv = xe^{x^2}, v = \frac{1}{2}e^{x^2}$

$$I_n = \left[ \frac{1}{2} x^{2n} e^{x^2} \right]_0^1 - n \int_0^1 x^{2n-1} e^{x^2} dx$$

$$= \frac{e}{2} - nI_{n-1}.$$

(ii)  $I_2 = \frac{e}{2} - 2I_1.$

$$I_1 = \frac{e}{2} - I_0$$

$$I_0 = \int_0^1 xe^{x^2} dx = \frac{1}{2} [e^{x^2}]_0^1 = \frac{1}{2}(e-1).$$

$$\therefore I_2 = \frac{e}{2} - 2 \left[ \frac{e}{2} - \frac{1}{2}(e-1) \right] = \frac{e}{2} - 1.$$

(c)

(i)  $f'(x) = \frac{e^x + e^{-x}}{2} - 1.$

$$f''(x) = \frac{e^x - e^{-x}}{2}.$$

For all  $x > 0, e^x > e^{-x}, \therefore f''(x) > 0.$

(ii) Since  $f''(x) > 0, f'(x)$  is increasing.

When  $x = 0, f'(0) = \frac{1+1}{2} - 1 = 0.$

$$\therefore f'(x) > 0 \text{ for all } x > 0.$$

(iii) Similarly, since  $f'(x) > 0, f(x)$  is increasing.

$$f(0) = \frac{1-1}{2} - 0 = 0.$$

$$\therefore f(x) > 0 \text{ for all } x > 0.$$

$$\therefore \frac{e^x - e^{-x}}{2} - x > 0 \text{ for all } x > 0.$$

$$\therefore \frac{e^x - e^{-x}}{2} > x \text{ for all } x > 0.$$

### Q6

(a) The shaded rectangle has sides  $2y$  and  $(4-x)$ .

$$\therefore \text{Area} = 2y(4-x).$$

$$\therefore \partial V = 2y(4-x)\partial x = 2\sqrt{(4-x)^3}\partial x, \text{ since}$$

$$y = \sqrt{4-x}.$$

$$\therefore V = 2 \int_0^4 \sqrt{(4-x)^3} dx$$

$$= 2 \left[ \frac{2\sqrt{(4-x)^5}}{-5} \right]_0^4 = \frac{4}{5} \times 32 = \frac{128}{5} \text{ units}^3.$$

(b)

(i) Let the roots be  $-1, \alpha$  and  $\beta$ .

$$\prod \alpha = -1 \times \alpha \times \beta = -1 \left( = -\frac{d}{a} \right).$$

$$\therefore \beta = \frac{1}{\alpha}.$$

(ii) Since all the coefficients are real,  $\bar{\alpha}$  is also a root.

$$\therefore \bar{\alpha} = \frac{1}{\alpha}.$$

$$\alpha \bar{\alpha} = 1.$$

$$\therefore |\alpha| = 1.$$

(iii) Let  $\alpha = a + ib$ , where  $a, b$  are real.

$$\sum \alpha = -1 + a + ib + a - ib = 2a - 1.$$

Since  $\sum \alpha = -q$ ,

$$2a - 1 = -q.$$

$$a = \frac{1 - q}{2}.$$

(c)

(i)  $PQ^2 = OP^2 - OQ^2 = x^2 + y^2 - r^2.$

$$\therefore PQ = \sqrt{x^2 + y^2 - r^2}.$$

(ii)  $PR = |x - c|$

$$\therefore \sqrt{x^2 + y^2 - r^2} = |x - c|.$$

$$x^2 + y^2 - r^2 = x^2 - 2cx + c^2.$$

$$y^2 = r^2 + c^2 - 2cx.$$

(iii)  $y^2 = -2c \left( x - \frac{r^2 + c^2}{2c} \right).$

$\therefore$  Type  $y^2 = -4aX$ , where  $4a = 2c, \therefore$  focal length  $= \frac{c}{2}.$

$\therefore$  Focus  $\left( \frac{r^2 + c^2}{2c} - \frac{c}{2}, 0 \right)$ , which is  $\left( \frac{r^2}{2c}, 0 \right).$

(iv) The directrix has equation  $x = \frac{r^2 + c^2}{2c} + \frac{c}{2} = \frac{r^2 + 2c^2}{2c}.$

By definition,  $PS = PM$ , where  $M$  is the foot of  $P$  on the directrix.

$$\therefore PS = PM = \left| x - \frac{r^2 + 2c^2}{2c} \right|$$

But  $PQ = PR = |x - c|.$

$$\therefore PS - PQ = \left| x - \frac{r^2 + 2c^2}{2c} \right| - |x - c|$$

$$= \frac{r^2 + 2c^2}{2c} - c = \frac{r^2}{2c}, \text{ which is independent of } x.$$

**Q7**

(a)

(i)  $\ddot{x} = \frac{v dv}{dx} = g - rv.$

$$\frac{v dv}{g - rv} = dx.$$

$$\int \frac{v dv}{g - rv} = \int dx.$$

$$-\frac{1}{r} \int \frac{g - rv - g}{g - rv} dv = \int dx.$$

$$-\frac{1}{r} \left( v + \frac{g}{r} \ln(g - rv) \right) = x + C.$$

When  $x = 0, v = 0, \therefore C = -\frac{g}{r^2} \ln g.$

$$\therefore -\frac{v}{r} - \frac{g}{r^2} \ln(g - rv) + \frac{g}{r^2} \ln g = x.$$

$$\therefore x = \frac{g}{r^2} \ln \left( \frac{g}{g - rv} \right) - \frac{v}{r}.$$

When  $x = L,$

$$L = \frac{9.8}{0.2^2} \ln \left( \frac{9.8}{9.8 - 0.2 \times 30} \right) - \frac{30}{0.2} = 82 \text{ m}.$$

(ii)  $v = \frac{dx}{dt} = -\frac{1}{10} e^{\frac{t}{10}} (29 \sin t - 10 \cos t) +$

$$e^{\frac{t}{10}} (29 \cos t + 10 \sin t).$$

When  $v = 0,$

$$\frac{29 \sin t - 10 \cos t}{10} = 29 \cos t + 10 \sin t.$$

$$29 \sin t - 10 \cos t = 290 \cos t + 100 \sin t.$$

$$300 \cos t = -71 \sin t.$$

$$\tan t = -\frac{300}{71}.$$

$$t = -1.34 \text{ or } \pi - 1.34 = 1.80.$$

When  $t = 1.80,$

$$x = e^{-0.18} (29 \sin 1.8 - 10 \cos 1.8) + 92$$

$$= 25.49 + 92 = 117.49 \text{ m}.$$

Given that his body length is 2 m,  $117.49 + 2 = 119.49$  m,

$\therefore$  the jumper's head still stays out of the water.

(b)

(i)  $z^n = \cos n\theta + i \sin n\theta.$

$$z^{-n} = \frac{1}{z^n} = \frac{1}{\cos n\theta + i \sin n\theta} = \frac{\cos n\theta - i \sin n\theta}{\cos^2 n\theta + \sin^2 n\theta}$$

$$= \cos n\theta - i \sin n\theta.$$

Alternatively,  $z^{-n} = \cos(-n\theta) + i \sin(-n\theta)$

$$= \cos n\theta - i \sin n\theta, \text{ since } \cos(-n\theta) = \cos n\theta$$

$$\text{and } \sin(-n\theta) = -\sin n\theta.$$

$$\therefore z^n + z^{-n} = 2 \cos n\theta.$$

(ii)  $(z + z^{-1})^{2m} = (2 \cos \theta)^{2m}.$

$$\text{LHS} = z^{2m} + \binom{2m}{1} z^{2m-1} z^{-1} + \binom{2m}{2} z^{2m-2} z^{-2} +$$

$$+ \binom{2m}{m-1} z^{m+1} z^{-m+1} + \binom{2m}{m} z^m z^{-m} + \binom{2m}{m+1} z^{m-1} z^{-m-1} +$$

$$+ \dots + \binom{2m}{2m-1} z^1 z^{-2m+1} + z^{-2m}$$

$$= (z^{2m} + z^{-2m}) + \binom{2m}{1} (z^{2m-2} + z^{-2m+2})$$

$$+ \binom{2m}{2} (z^{2m-4} + z^{-2m+4}) + \dots + \binom{2m}{m-1} (z^2 + z^{-2}) + \binom{2m}{m}$$

$$= 2 \cos 2m\theta + \binom{2m}{1} 2 \cos(2m-2)\theta$$

$$\begin{aligned}
 & + \binom{2m}{2} 2 \cos(2m-4)\theta + \dots + \binom{2m}{m-1} 2 \cos 2\theta + \binom{2m}{m} \\
 & = 2 \left[ \cos 2m\theta + \binom{2m}{1} \cos(2m-2)\theta \right. \\
 & \left. + \binom{2m}{2} \cos(2m-4)\theta + \dots + \binom{2m}{m-1} \cos 2\theta \right] + \binom{2m}{m} \\
 \text{(iii)} \quad & 2^{2m} \int_0^{\frac{\pi}{2}} (\cos \theta)^{2m} d\theta = 2 \left[ \frac{\sin 2m\theta}{2m} + \binom{2m}{1} \frac{\sin(2m-2)\theta}{2m-2} \right. \\
 & \left. + \binom{2m}{2} \frac{\sin(2m-4)\theta}{2m-4} + \dots + \binom{2m}{m-1} \frac{\sin 2\theta}{2} \right]_0^{\frac{\pi}{2}} \\
 & + \left[ \binom{2m}{m} \theta \right]_0^{\frac{\pi}{2}} \\
 & = \binom{2m}{m} \frac{\pi}{2}, \text{ since sine of a multiple of } \pi = 0. \\
 \therefore \int_0^{\frac{\pi}{2}} (\cos \theta)^{2m} d\theta & = \frac{1}{2^{2m}} \binom{2m}{m} \frac{\pi}{2} \\
 & = \frac{\pi}{2^{2m+1}} \binom{2m}{m}.
 \end{aligned}$$

**Q8**

(a)

(i) Let  $t = \tan \frac{\theta}{2}$ ,

$$\begin{aligned}
 \cot \theta + \frac{1}{2} \tan \frac{\theta}{2} & = \frac{1-t^2}{2t} + \frac{t}{2} = \frac{1-t^2+t^2}{2t} = \frac{1}{2t} \\
 & = \frac{1}{2} \cot \frac{\theta}{2}.
 \end{aligned}$$

(ii) Let  $n=1$ , LHS =  $\tan \frac{x}{2}$ ,

$$\begin{aligned}
 \text{RHS} & = \cot \frac{x}{2} - 2 \cot x = 2 \cot x + \tan \frac{x}{2} - 2 \cot x \\
 & = \tan \frac{x}{2}, \text{ since from (i), } \frac{1}{2} \cot \frac{x}{2} = \cot x + \frac{1}{2} \tan \frac{x}{2}, \\
 \therefore \cot \frac{x}{2} & = 2 \cot x + \tan \frac{x}{2}. \\
 \therefore \text{True for } n & = 1.
 \end{aligned}$$

Assume  $\tan \frac{x}{2} + \frac{1}{2} \tan \frac{x}{2^2} + \frac{1}{2^2} \tan \frac{x}{2^3} + \dots$

$$\begin{aligned}
 & + \frac{1}{2^{n-1}} \tan \frac{x}{2^n} = \frac{1}{2^{n-1}} \cot \frac{x}{2^n} - 2 \cot x. \\
 \text{RTP: } \tan \frac{x}{2} + \frac{1}{2} \tan \frac{x}{2^2} + \frac{1}{2^2} \tan \frac{x}{2^3} + \dots \\
 & + \frac{1}{2^n} \tan \frac{x}{2^{n+1}} = \frac{1}{2^n} \cot \frac{x}{2^{n+1}} - 2 \cot x. \\
 \text{LHS} & = \frac{1}{2^{n-1}} \cot \frac{x}{2^n} - 2 \cot x + \frac{1}{2^n} \tan \frac{x}{2^{n+1}}
 \end{aligned}$$

$$\begin{aligned}
 & = \frac{1}{2^{n-1}} \left( \cot \frac{x}{2^n} + \frac{1}{2} \tan \frac{x}{2^{n+1}} \right) - 2 \cot x \\
 & = \frac{1}{2^{n-1}} \times \frac{1}{2} \cot \frac{x}{2^{n+1}} - 2 \cot x \\
 & = \frac{1}{2^n} \cot \frac{x}{2^{n+1}} - 2 \cot x = \text{RHS}.
 \end{aligned}$$

$\therefore$  It's true for  $n+1$ .

Hence, it's true for all  $n \geq 1$ .

(iii) As  $n \rightarrow \infty, \frac{x}{2^n} \rightarrow 0, \therefore \frac{\tan \frac{x}{2^n}}{\frac{x}{2^n}} \rightarrow 1$ .

$$\begin{aligned}
 \therefore \frac{1}{2^{n-1}} \cot \frac{x}{2^n} - 2 \cot x & = 2 \times \frac{\frac{x}{2^n}}{\tan \frac{x}{2^n}} \times \frac{1}{x} - 2 \cot x \\
 & \rightarrow \frac{2}{x} - 2 \cot x.
 \end{aligned}$$

(iv) Let  $x = \frac{\pi}{2}$ ,

$$\begin{aligned}
 \sum_{r=1}^{\infty} \frac{1}{2^{r-1}} \tan \frac{\pi}{2^{r+1}} & = \tan \frac{\pi}{4} + \frac{1}{2} \tan \frac{\pi}{8} + \frac{1}{4} \tan \frac{\pi}{16} + \dots \\
 & = \lim_{n \rightarrow \infty} \left( \frac{1}{2^{n-1}} \cot \frac{\pi}{2^{n+2}} \right) - 2 \cot \frac{\pi}{2} \\
 & = \frac{2}{\frac{\pi}{2}} - 2 \cot \frac{\pi}{2} - 2 \cot \frac{\pi}{2} \\
 & = \frac{4}{\pi}.
 \end{aligned}$$

(b)  $\frac{1}{n} < \int_{n-1}^n \frac{1}{x} dx < \frac{1}{n-1}$ .

$$\frac{1}{n} < [\ln x]_{n-1}^n < \frac{1}{n-1}.$$

$$\frac{1}{n} < \ln \frac{n}{n-1} < \frac{1}{n-1}.$$

$$e^{\frac{1}{n}} < \frac{n}{n-1} < e^{\frac{1}{n-1}}.$$

$$e^{-\frac{1}{n-1}} < \frac{n-1}{n} < e^{-\frac{1}{n}}, \text{ noting that if } a < b \text{ then } \frac{1}{b} < \frac{1}{a},$$

$$e^{-\frac{n}{n-1}} < \left( \frac{n-1}{n} \right)^n < e^{-1}, \text{ by raising to the power } n.$$

(c)

(i) The probability that a person draws his/her own card is

$$p = \frac{1}{n}, \therefore \text{the probability that he/she does not draw his/her}$$

$$\text{own card is } q = 1 - \frac{1}{n}.$$

$$\Pr(A_1 \text{ wins in the first draw}) = p$$

$$\Pr(A_1 \text{ wins in the second draw, i.e. after}$$

$$\text{a round that no one draws own card}) = q^n p$$

$\Pr(A_1 \text{ wins in the third draw, i.e. after}$

two rounds that no one draws own card)  $= q^{2n} p$

$\Pr(A_1 \text{ wins}) = p + q^n p + q^{2n} p + \dots$

$= \frac{p}{1 - q^n}$  (using the limiting sum of a GP, since

the ratio  $= q^n < 1$ )

$$\therefore W = \frac{p}{1 - q^n}.$$

$$W - q^n W = p.$$

$$\therefore W = p + q^n W.$$

(ii)  $W_m = p + q^n p + q^{2n} p + \dots + q^{(m-1)n} p$

$$= \frac{p(1 - q^{mn})}{1 - q^n}.$$

$$\therefore \frac{W_m}{W} = \frac{\frac{p(1 - q^{mn})}{1 - q^n}}{\frac{p}{1 - q^n}} = 1 - q^{mn}$$

$$= 1 - \left(1 - \frac{1}{n}\right)^{mn}$$

If  $n$  is large,  $\frac{n}{n-1} \approx 1$ ,  $\therefore$  the result in (b) becomes

$$e^{-\frac{n}{n-1}} \approx e^{-1} < \left(1 - \frac{1}{n}\right)^n < e^{-1}.$$

$$\therefore \left(1 - \frac{1}{n}\right)^n \approx e^{-1}.$$

$$\therefore \left(1 - \frac{1}{n}\right)^{mn} \approx e^{-m}.$$

$$\therefore \frac{W_m}{W} \approx 1 - e^{-m}.$$

